LonWorks Fundamentals

A Guide to a Basic Understanding of the
LonTalk Protocol

North Beach Consulting, LLC

11217 Eastborough Ct.
Richmond, VA 23233
Telephone: (804) 270-7092

Copyright Notice: This document may not, in whole or in part, be copied, photocopied, reproduced, translated, or reduced to any electronic medium or machine-readable form without prior written consent from:

North Beach Consulting, LLC
11217 Eastborough Ct.
Richmond, Virginia 23233

While every effort has been made to assure the accuracy of this document, North Beach Consulting, LLC shall not be held responsible for damages, including consequential damages, arising from the application of the information given herein. The information in this document is subject to change without notice.

Trademark Notices: Microsoft and Windows are registered trademarks, and Windows 95, Windows NT, Windows 2000, Windows XP, and Internet Explorer are trademarks of Microsoft Corporation. Echelon, LON, LonMark, LonTalk, and LonWorks are registered trademarks of Echelon Corporation. Tridium Niagara, the Niagara Framework, Vykon, WorkPlace Pro, Web Supervisor, JACE-4, JACE-5, and JACE-NP are trademarks of Tridium Inc.

All other product names and services mentioned in this publication that are known to be trademarks, registered trademarks, or service marks have been appropriately capitalized and are the properties of their respective owners.

LonWorks Fundamentals
© 2003, North Beach Consulting, LLC
All rights reserved.

LonWorks Fundamentals

A Guide to a Basic Understanding of the LonTalk Protocol

Overview

This document introduces the LonWorks technology, the company that created it (Echelon), and the LonMark Association, which is devoted to developing standards for interoperability in control system networks.

This document can be read in advance of, or in combination with, technical training relating to support of building automation systems employing the LonTalk protocol. This document is intended for anyone desiring a basic understanding of LonWorks networks.

The following topics are addressed:

- An overview of LonWorks technology.
- An overview of the LonMark Association.
- Basic design of LonWorks nodes including a discussion of the Neuron chip, communications transceivers, media, and network topology.
- Channels, repeaters, and routers.
- An overview of user interface requirements.
- Logical addressing including a discussion of domains, subnets, and node addressing.
- An overview of how LonWorks devices share data including standard network variables types (SNVT) and LonTalk bindings.
- A discussion of configuration parameters including standard configuration parameter types (SCPT) and user-defined configuration parameter types (UCPT).
- Functional profiles and program IDs.

LonWorks

LonWorks is the name given to the collective technology developed by the Echelon Corporation for implementing control system networks. The root term, LON, is an acronym for local operating network, which refers to an intelligent control network that facilitates communications between devices or nodes that communicate with one another over a variety of transmission media using a common, message-based control protocol.

Echelon's design endeavors to provide an off-the-shelf method for manufacturers to build devices that can coexist and operate as peers on a flat, interoperable control network.

LonMark

If a device is designed to use the LonWorks technology, depending on the implementation, it may or may not interoperate with other LonWorks devices. Simply using the LonWorks technology does not guarantee interoperability. The LonMark certification is granted through the LonMark Association, which is a large, relatively independent organization of manufacturers, suppliers, and end users from around the world. The organization develops technical product specifications and guidelines that promote interoperability among participating equipment manufacturers. Participation of this nature promotes interconnection and intercommunication with other products. LonMark refers to the mark signifying that a product has met LonMark guidelines that allow it to interoperate with other LonMark devices on a LON.

LonWorks Nodes

The term *node* refers to a LonWorks device. Manufacturers of LonWorks devices adhere to the LonTalk protocol when designing and building these products – also referred to as smart devices. LonWorks devices contain a Neuron chip and a communications transceiver.

Neuron Chip

The central component of an Echelon node is the Neuron chip. Each Neuron chip contains three 8-bit, in-line CPUs, on-board memory, eleven general-purpose I/O pins, and a complete interoperable implementation of the LonTalk protocol. In fact, on Neuron-based nodes, the Neuron chip alone does the vast majority of the work performed by the node. Except for the power supply, I/O devices, and some of the transceiver functions, all work performed by the node is done by the Neuron chip.

Figure 1. Neuron Chip.

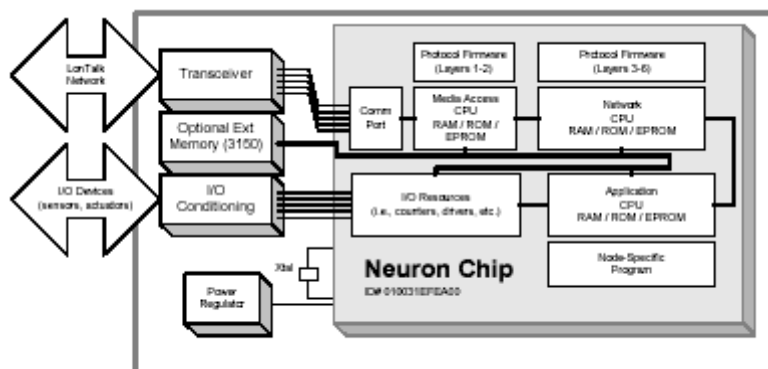

The Neuron chip performs several different duties at once. It is a processor, a device controller, a memory chip, and it has built-in EEPROM that contains network configuration

and addressing information, a unique permanently programmed 48-bit serial number, and optional user-written application code.

Transceivers, Media, and Network Topology

In addition to the Neuron chip, LonWorks nodes require one of several transceiver modules, which provide interface between the Neuron chip and the LonWorks fieldbus. Transceivers are manufactured by Echelon and they provide connectivity for virtually every transmission media including twisted pair, power line, RF, infrared, coaxial cable, and fiber.

Probably the most versatile and popular transceiver is the **FTT-10 Free Topology** transceiver, which supports twisted pair, unshielded, polarity-insensitive, peer-to-peer communications at 78 Kbps. The Free Topology approach allows any number of tees, stars, loops, or bus combinations in a wiring segment.

Segment

The term *segment* refers to a single piece of uninterrupted wire. A segment supports up to 64 devices.

Wiring Topologies

There are two broad categories of wiring topologies supported by FTT-10: Free Topology and Doubly Terminated.

The combined lengths of cable connecting the various devices on the LonWorks network in a Free Topology approach is limited to 500 meters (1640 feet) and requires a single termination module installed anywhere on the segment.

In a Doubly Terminated approach, all twisted pair wiring is done in a linear bus or daisy-chain fashion that does not support wiring tees of any sort. Each physical end of the segment must be terminated using a termination module and the maximum bus length depends on wire size (i.e., 1400 meters or 4590 feet using 22 AWG).

Channels, Repeaters, and Routers

The term *channel* is an Echelon term used to describe the physical medium to which a node is attached and the transceiver type it uses to communicate. Although the LonTalk protocol supports networks with segments using different media (channels), all devices on a given channel must communicate using the same type of transceiver. Every LonWorks node is physically connected to a channel. The physical form of a channel depends on the medium: a twisted pair channel is a twisted pair wire; an RF channel is a specific radio frequency; a power line channel is a continuous section of AC power wiring, and so on.

A *repeater* is used to amplify incoming signal strength and send it on – it does not do any selective routing. A single wiring segment supports up to 64 nodes (FTT-10 transceivers), but a channel can span multiple segments that employ physical layer repeaters to expand both the number of nodes and the length of the control network. Depending on the

application and expected network performance (in terms of response time), the maximum number of nodes supported by a LonWorks network is 32,385.

Routers are used to manage network message traffic, extend the physical size of a channel (both in terms of length and the number of devices attached), and to connect channels that use different media (transceiver types). Routers consist of a pair of Neurons and transceivers each watching a separate channel – they attach two channels and selectively route packets between them. Routers can be configured using one of four routing algorithms that employ varying degrees of intelligence including repeater, bridge, configured router, and learning router.

Figure 2. Network Topology.

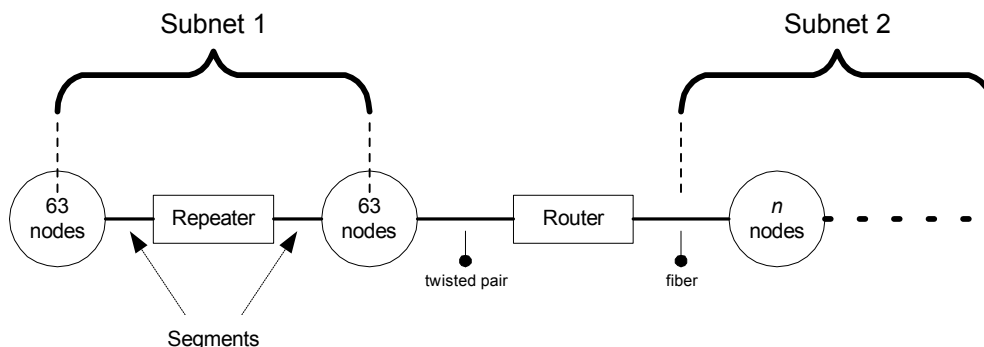

Repeaters:

- Used to extend the capacity of the network beyond 63 nodes.

Routers:

- Used when the node count exceeds 127.
- Used when the wire length exceeds maximum distance (500m or 1400m).
- Partition traffic between sections of a network, thereby reducing traffic).
- Converts from one media type to another (i.e., twisted pair to fiber).

Subnet:

- A subnet is a logical grouping of up to 127 devices.

User Interface

A workstation (PC) can be used to interface to a network of LonWorks devices. It must contain a LonWorks communications adapter and software. Connectivity can be by serial connection via a LonWorks SLTA (Serial LonTalk Adapter) card and modem or by PCC-10 card, which provides direct connection to the LonWorks fieldbus. The workstation counts as a node on the network.

Logical Addressing

To simplify routing, the LonTalk protocol defines a hierarchical form of address to logically address each node. In the process known as *network management*, software is used to associate the node's unique 48-bit Neuron ID to a logical domain, subnet, and node (DSN) number.

The components of a logical address include the following.

Domain

The highest level of the addressing hierarchy is the domain level. Nodes must be on the same domain to communicate, but if different network applications exist on the same transmission medium, different domain identifiers can be used to keep the applications separate. Each node can be a member of up to two domains.

Subnet

The second level of addressing is the subnet. A subnet is a logical grouping of up to 127 nodes from one or more channels. Each domain can have up to 255 subnets.

Node Address

Each node must have a unique node number on a subnet. Up to 127 nodes can exist on a subnet.

The transmission medium (channel) does not affect the way a node is logically addressed. Domains can contain several channels, as can subnets and groups. All communications consist of one or more packets that are exchanged between devices. Every node on the channel looks at every packet transmitted on the channel to determine if it is intended for that node. If the node finds that the packet is addressed to that node, it dissects the message to determine if it contains data for an application running in the node or if it contains network management information. Depending on the content of the message, the receiving node responds with an acknowledgement, a response, or an authentication message.

Network Variables

Echelon defines a network variable as a data item that a particular device application program expects to get from other devices on a network (a network variable input or NVI) or expects to make available to other devices on a network (a network variable output or NVO). Examples of network variables might include zone temperature, discharge air temperature, relative humidity, switch position, and occupied/unoccupied mode.

Network variable *binding* allows devices to share data.

SNVT

In order for applications from multiple manufacturers to easily interoperate, their network variables must be interpreted in the same way. The LonMark organization has defined and published common system variables, called standard network variable types (SNVTs – pronounced “sniv-its”). Each SNVT has standardized properties that are used to define variables shared on the network. These properties include variable context (temperature, address, etc.), unit of measure (degrees, volts, etc.), and dimension (gallons, GPM, KGPH, etc.).

SNVTs can be any single data item, or they can be data structures. An example of a network variable that uses data structures is **SNVT_temp_setpt**, which contains six setpoints.

Bindings

In order for LonWorks devices to share data (interoperate), network variables have the ability to be bound one to another on the network. There are two rules associated with binding network variables:

- To bind two network variables, one must be an output (NVO) and the other must be an input (NVI). An NVO can be bound to multiple NVIs.
- To bind two network variables, the SNVTs of the variables must match. This ensures compatibility of the information.

An example of a network variable binding might include the space temperature output measured by a thermostat bound to the space temperature input of one or more VAV controllers controlling that variable.

Bound SNVTs allow for peer-to-peer communications between LonWorks devices – no area controller is required.

Configuration Parameters

Configuration parameters are specific pieces of information that are used to define node behavior. For instance, configuration properties are often used to define alarm limits and operating limits.

There are two types of configuration parameters.

SCPT

Standard configuration parameter types – pronounced “skip-its”. These are defined by the LonMark Association and are used by manufacturers to define common configuration data. Examples of SCPTs include setpoint, default values, minimum and maximum limits, gain settings, and delay time.

UCPT

User-defined configuration parameter types. As needed, manufacturers can define their own configuration parameters. If used, manufacturers must document UCPTs in the data resource files associated with a device.

Functional Profiles

Where standard network variable types define the data within network variables, a higher level of standardization defines functionality for devices. This level of standardization is referred to as a *functional profile*. Device manufacturers use profiles to make public the network variables, configuration properties, default behavior, and power-up behavior for the devices that they manufacture. Profiles standardize functional behavior, not products, and no matter who manufactures a complimentary LonMark device, the two devices will be able to share data. Moreover, interface to the device becomes more predictable and consistent.

As illustrated in Figure 3, an example of a functional profile might be that of a heat pump.

Figure 3. Functional Profile

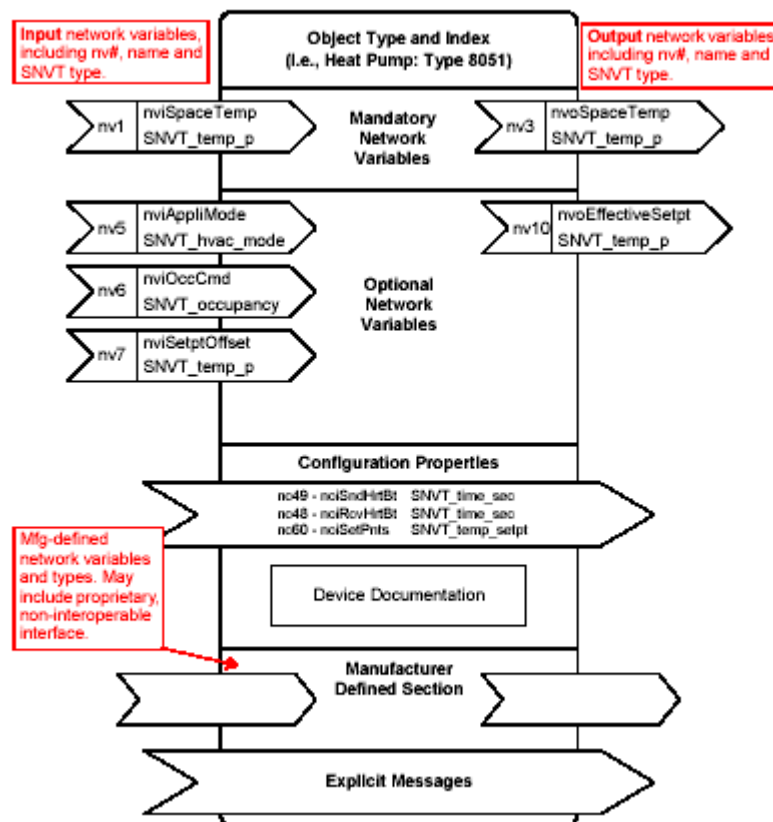

Program IDs

A program ID is a unique identifier for the device functionality that is included in a LonWorks device. Devices that have been certified by the LonMark Association contain program IDs in a standard format that includes manufacturer, device functionality, the transceiver type used, and documentation relating to the intended use of the device. Program IDs are used by network management tools to identify nodes on the LonWorks network.

Program IDs are 8-byte identifiers (for example: 80:0:C:50:5A:3:4:12) that include: format, manufacturer ID, device class, device subclass, and model number.

Format: A 4-bit value that defines the structure of the program ID. Formats include:

- Formats 8 and 10-15 are reserved for interoperable LonMark devices that have already passed a certification review.
- Format 9 is reserved for devices that have applied for but not passed a certification review. These devices are typically in development, prototype, or field test.

Manufacturer ID: Identifies the manufacturer of the device using their assigned manufacturer number. Manufacturers are assigned an ID when they join the LonMark Association. Manufacturers that do not yet belong to the association can use ID zero.

Device Class: Device class is drawn from a pre-defined registry of class definitions that indicate the primary function of the device. If a new device class is needed, the manufacturer can apply to the LonMark Association.

Device Subclass: Device subclass is drawn from a pre-defined registry of subclass definitions within a given device class. Device subclass indicates the transceiver type used and the intended use of the device. If a new device subclass is needed, the manufacturer can apply to the LonMark Association.

Model Number: Model numbers are assigned by the manufacturer and must be unique within the device class and subclass for the manufacturer. This model number does not have to necessarily need to conform to the actual model number used by the manufacturer.

For More Information

For more detailed information about LonWorks network management tools including using the LonWorks service for a Niagara station, refer to the *LonWorks Integration Reference* from Tridium, Inc.